

Super Chipmunk - 90S



0.60 cu.in. displacement 2-cycle
0.90 cu.in. displacement 4-cycle
 Radio required : 6 channels, 7 servos airplane radio

Specifications

Wing Span	64.0 in / 1620 mm
Wing Area	682 sq in / 44.0 sq dm
Flying Weight	7.5 lbs / 3400 g
Fuselage Length	53.0 in / 1340 mm

* Specifications are subject to change without notice.*

Warning ! This model is not a toy.

It is designed for maximum performance. Please seek advice if one is not familiar with this kind of engine powered precision model. Operating this model without prior preparation may cause injuries. Remember, safety is the most important thing. Always keep this instruction manual at hand for quick reference.



**THE WORLD MODELS
 MANUFACTURING CO. LTD.**
 FACTORY PRE-FABRICATED
 ALMOST-READY-TO-FLY (ARF) SERIES
 MADE IN CHINA
www.theworldmodels.com

Super Chipmunk - 90S

INDEX

BEFORE YOU BEGIN	-----	P.1
PARTS LIST	-----	P.2
ASSEMBLY	-----	P.3-11
SAFETY PRECAUTIONS	-----	P.11

BEFORE YOU BEGIN

- 1** Read through the manual before you begin , so you will have an overall idea of what to do.
- 2** Check all parts . If you find any defective or missing parts contact your local dealer. Please **DRY FIT** and check for defects for all parts that will require CA or Epoxy for final assembly. Any parts you find to be defective after the gluing process may be difficult to remove for warranty replacement. The manufacturer will replace any defective parts, but will be difficult to extend to the good parts that are good before gluing to defective parts during assembly.
- 3** Symbols used throughout this instruction manual comprise of the following:-

AB Apply epoxy glue.

C.A Apply instant glue
(C.A. glue,super glue.)

L/R Assemble left and right
sides the same way.

 Ensure smooth non-binding
movement while assembling.

 Peel off shaded portion
covering film.

 Cut off shaded portion.

 Drill holes with the specified
diameter(here:3mm)

N.I. Must be purchased separately!

 Pay close attention here!

 **Warning!**

 Pierce the shaded portion
covering film.

Do not overlook this symbol!

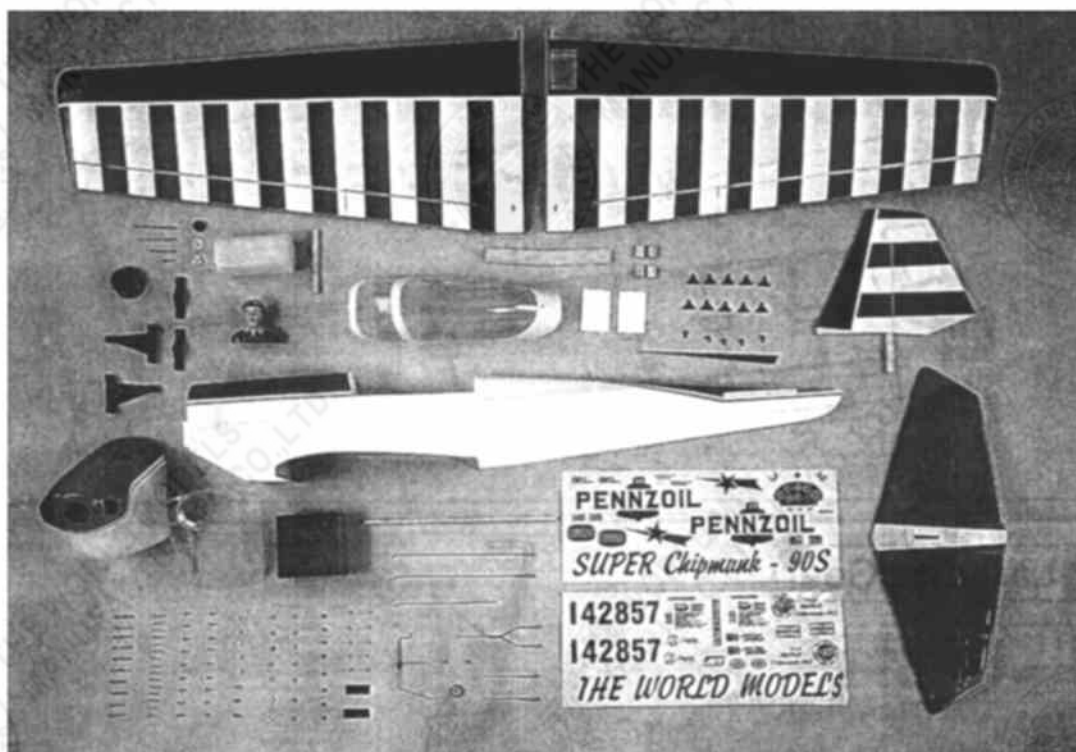

Parts List

1. FUSELAGE -- 1 pc.
2. MAIN WING -- 1 pair
3. STABILIZER & ELEVATOR -- 1 set
4. VERTICAL FIN & RUDDER -- 1 set
5. CANOPY -- 1 pc.
6. PILOT -- 1pc.
7. COWLING
TRANSPARENT DUMMY COWLING -- 1 pc.
8. SPINNER $\varnothing 57\text{mm}$ -- 1pc.
9. ENGINE MOUNT PL5111-070 -- 1set
10. FUEL TANK 380cc -- 1set
11. SPONGE (For Radio Equipment) -- 1pc.
12. TAIL LANDING GEAR -- 1set
13. MAIN WHEEL $\varnothing 58\text{mm}$
14. TAIL WHEEL $\varnothing 23\text{mm}$
15. PUSHROD:--
Balsa Rod $\varnothing 8 \times 340\text{mm}$ (For Elevator Servo) -- 1pc.
Metal Rod $\varnothing 1.8 \times 75\text{mm}$ w/Threads (For Aileron Servo) -- 2 pcs
Metal Rod $\varnothing 1.8 \times 180\text{mm}$ (For Elevator Servo) -- 1pc.
Metal Rod $\varnothing 1.8 \times 225\text{mm}$ w/Threads (For Elevator Servo) -- 1pc.
Metal Rod $\varnothing 1.8 \times 235\text{mm}$ w/Threads (For Elevator Servo) -- 1pc.
Metal Rod $\varnothing 1.8 \times 131\text{mm}$ Y-style w/Threads (For Flap Servo) -- 1pc.
Metal Rod $\varnothing 1.8 \times 610\text{mm}$ w/Threads (For Rudder Servo) -- 1pc.
16. THROTTLE PUSHWIRE $\varnothing 1.2 \times 440\text{mm}$ w/Plastic tube -- 1set
17. WOODEN PARTS:--
Balsa $8 \times 8 \times 112\text{mm}$ (For Fixing Fuel Tank) -- 1pc.
Balsa $8 \times 18 \times 21\text{mm}$ (For Aileron Servo) -- 4pcs
Balsa $8 \times 8 \times 146\text{mm}$ (For Servo Stand) -- 2pcs
Plywood $3 \times 65 \times 76\text{mm}$ (Aileron Servo Cover) -- 2pcs
Plywood $6 \times 107 \times 154\text{mm}$ (Servos Stand) -- 1pc.
Wooden $9 \times 24 \times 223\text{mm}$ (Wing Joiner) -- 1pc.
18. PLASTIC PARTS:--
CLEVIS -- 7 pcs
RING $\varnothing 2.6\text{mm}$ -- 2pcs
STRAPER -- 4 pcs
TRI-HORN $3 \times 9\text{mm}$ (For Aileron) -- 2sets
TRI-HORN $3 \times 14\text{mm}$ (For Rudder) -- 1set
TRI-HORN $3 \times 22\text{mm}$ (For Elevator) -- 2sets
SILICON GROMMET $d1.5 \times D6.5\text{mm}$
(For Cowling & Canopy) -- 10pcs
19. METAL PARTS:--
LINKAGE CONNECTOR 2.1mm -- 4 sets
COLLAR 2.1mm -- 2sets
COLLAR 4.1mm -- 2 sets
NUT 4mm -- 8pcs
SCREW PA3 $\times 8 \text{ mm}$ -- 2pcs
SCREW PM2 $\times 16 \text{ mm}$ -- 11pcs
SCREW PM2 $\times 20 \text{ mm}$ -- 4pcs
SCREW PM4 $\times 25 \text{ mm}$ -- 4pcs
SCREW PM4 $\times 30 \text{ mm}$ -- 4pcs
SCREW PM4 $\times 35 \text{ mm}$ -- 2pcs
SCREW PWA2.3 $\times 8\text{mm}$ -- 4pcs
SCREW PWA2.3 $\times 12\text{mm}$ -- 8pcs
SCREW PWA2.6 $\times 12\text{mm}$ -- 6pcs
WASHER $d4 \times D9\text{mm}$ -- 12pcs
WASHER $d4 \times D15\text{mm}$ -- 2pcs
20. FUEL TUBE $\varnothing 6 \times 5\text{mm}$ -- 11pcs
HEAT-SHRINK TUBE $\varnothing 8 \times 40\text{mm}$ -- 2pcs
21. DECALS -- 1set

1 Aileron

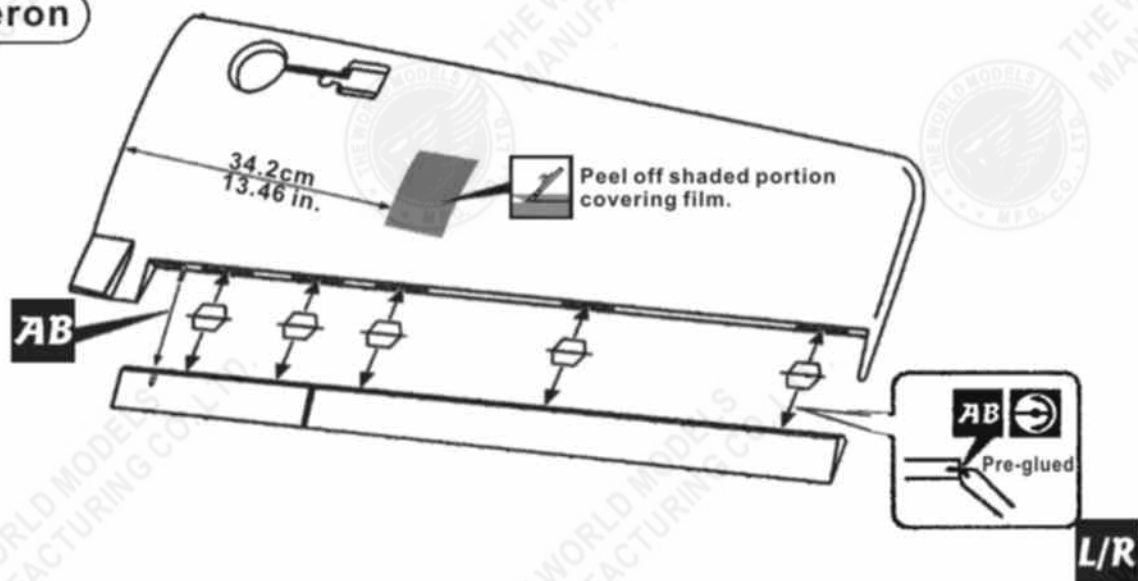

2 Landing Gear

KA3 x 14mm Screw
8

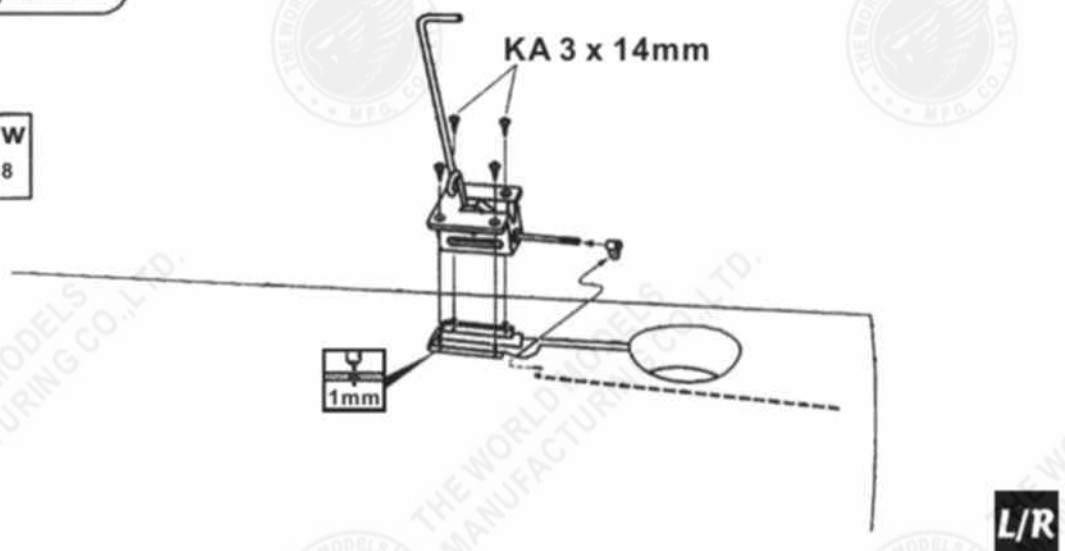

3 Landing Gear

3mm Set Screw 2
4.1mm Collar 2

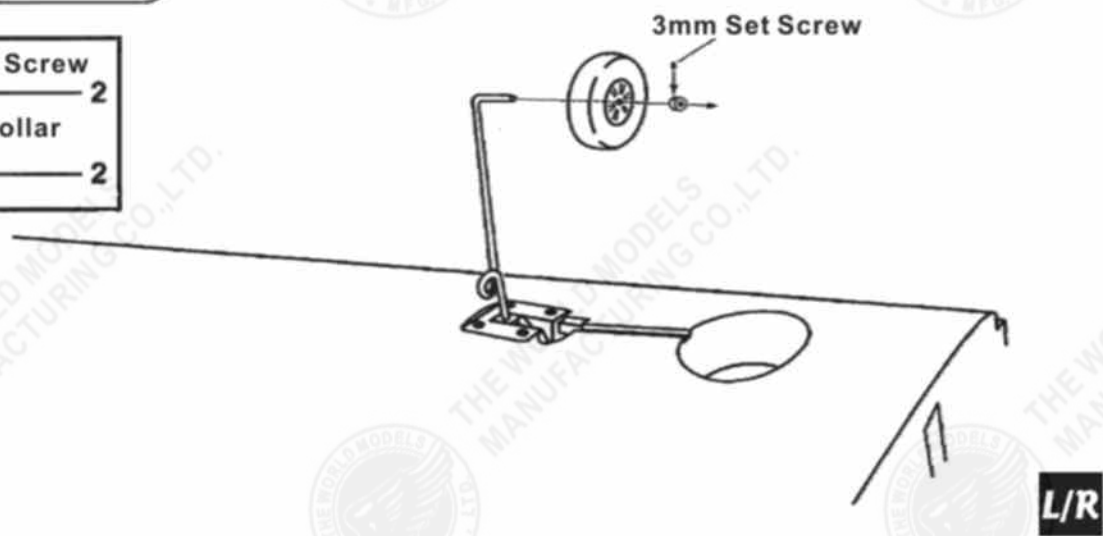

4 Aileron Servo

PWA2.3 x 12mm Screw 8

Aileron Servo Cover
3 x 65 x 76mm

N.I.
Aileron servo
extension cord.

PWA2.3 x 12mm

Balsa Wood
8 x 18 x 21mm

AB

Peel off shaded Portion
covering film.

L/R

5 Aileron Servo

PM2 x 16mm Screw 2

PM2 x 20mm Screw 4

PM2 x 20mm
PM2 x 16mm
PM2 x 20mm
Fuel Tube
Tri-horn
3 x 9mm

Straper

Fuel Tube

Ø1mm pilot holes for world models tri-horn
pre-drilled. Please look for pin-hole marks
at under side of control surfaces.

L/R

6 Main Wing

Peel off shaded portion
covering film for lead to
another aileron servo.

Peel off shaded
portion covering film.
For Flap Servo

Lead to Aileron Servo.

7 Landing Gear Servo

LINKAGE CONNECTOR

- 3 x 3mm Set Screw — 2
- Linkage Connector — 2
- 2mm Nut — 2
- 2mm Washer — 4

N.I. Gear Servo

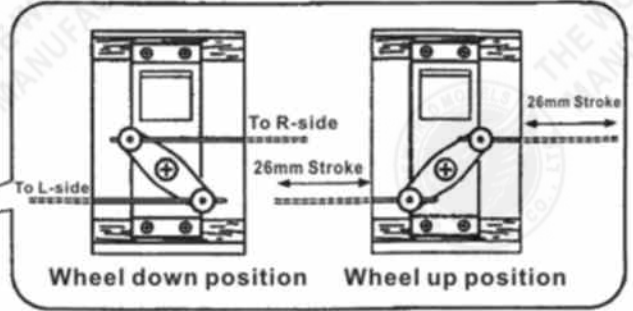

8 Flap Servo

N.I.

Peel off shaded portion covering film.

9 Flap Servo

Straper

Fuel Tube
Ø6 x 5mm - 3pcs

Clevis Ring

10 Stabilizer

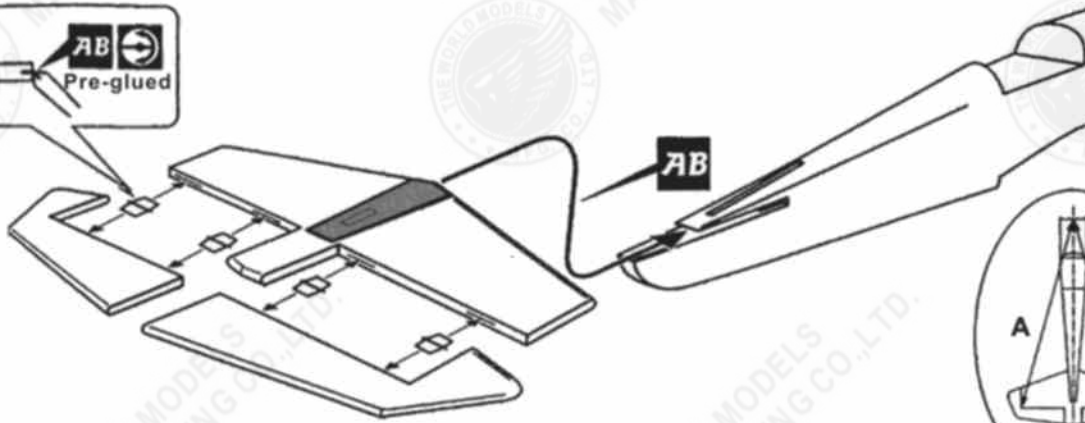

11 Vertical Fin / Rudder

- PA3 x 8mm Screw 2
- 3mm Set Screw 2
- 2.1mm Collar 2

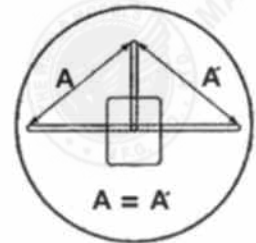
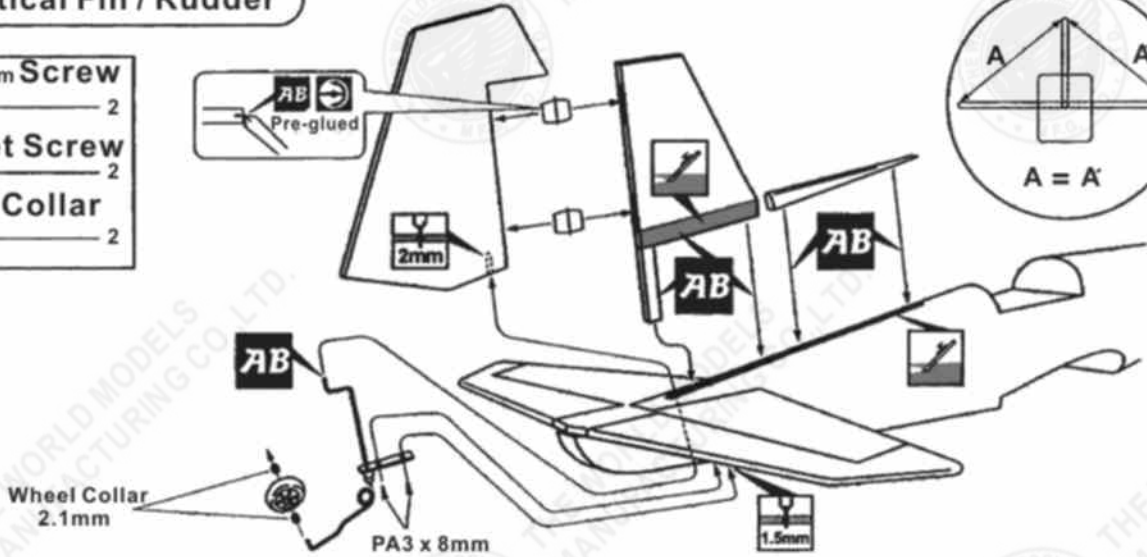

12 Fuel Tank

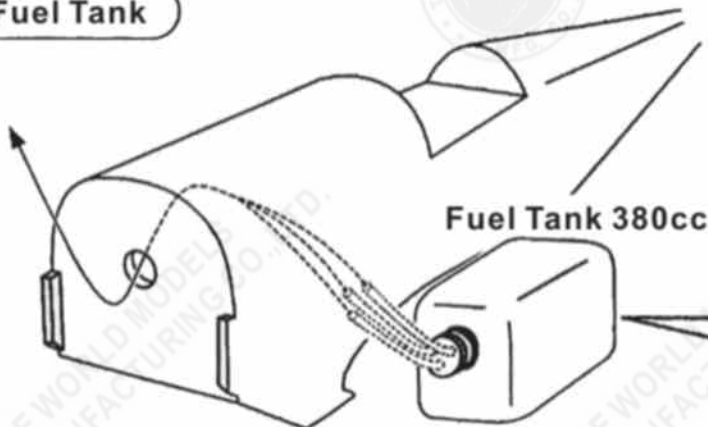

Install Balsa 8 x 8 x 112mm
(For fixing fuel tank)

Fuel Tank

● Bottom View

13 Engine Mount

PM4 x 25mm Screw	4
4mm Washer	4

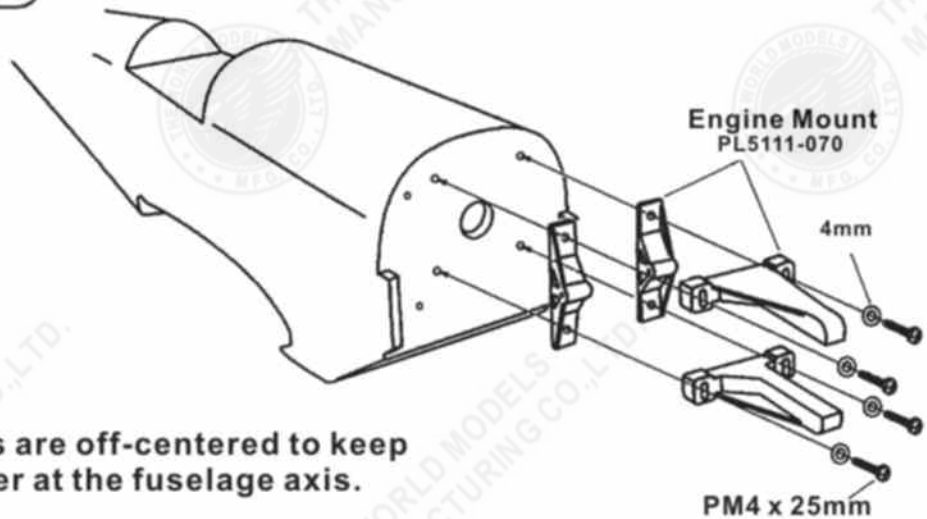

! Blind nuts are off-centered to keep the spinner at the fuselage axis.

14 Engine

PM4 x 30mm Screw	4
4mm Washer	8
4mm Nut	8

! Illustration is for side mounting. You can mount the engine upright engine mount. Thrust angles will not be affected.

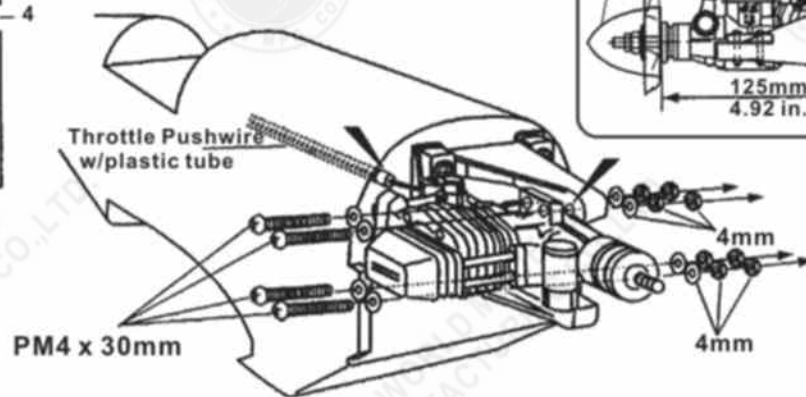
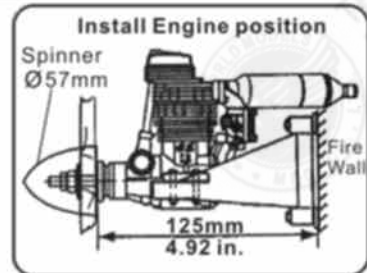

15 Cowling

PWA2.6 x 12mm Screw	6
d1.5 x D6.5mm Silicon Grommet	6

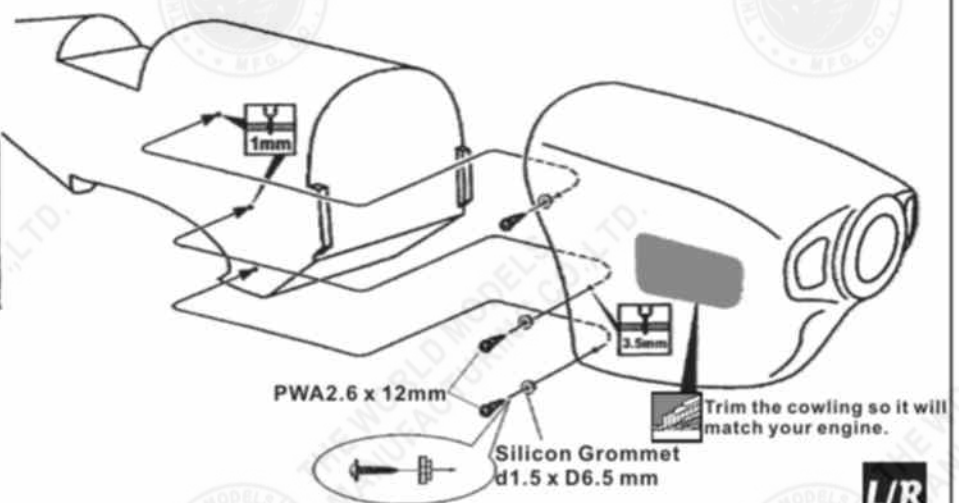

16 Elevator Pushrod

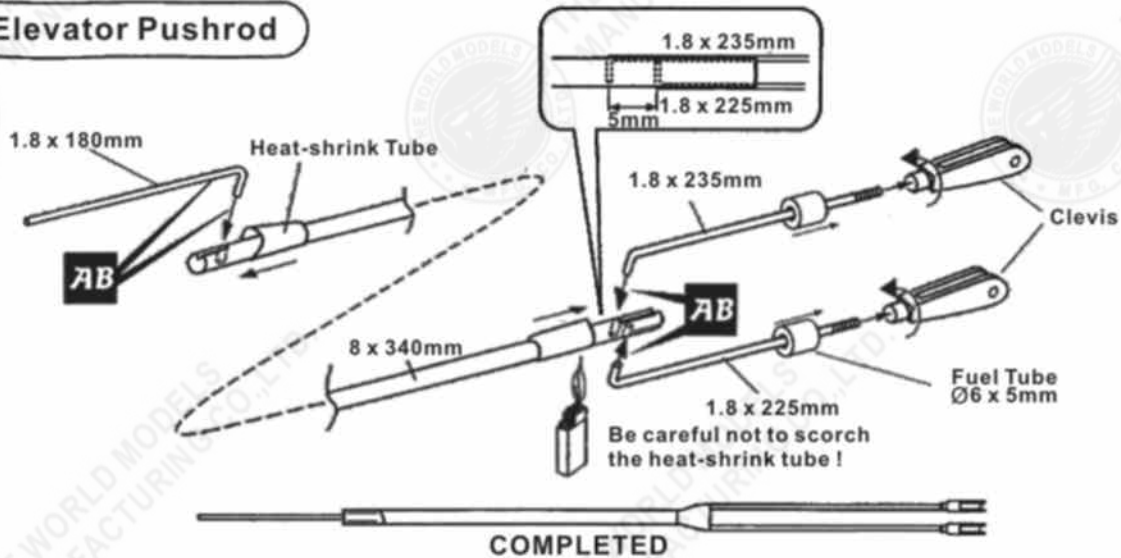

17 Servo Set

LINKAGE CONNECTOR

3 x 3mm Set Screw 2

Linkage Connector 2

2mm Nut 2

2mm Washer 4

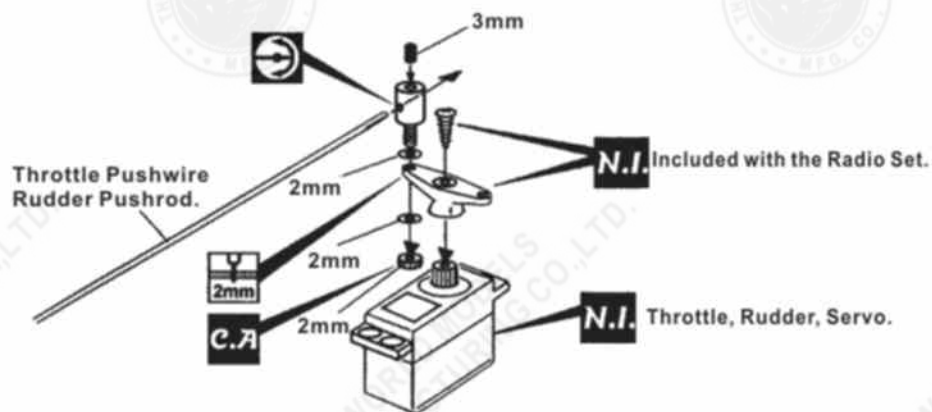

! Please refer to attached sheet for linkage connector installation.

18 Radio Equipment

Install and arrange the servo as shown in the diagram.

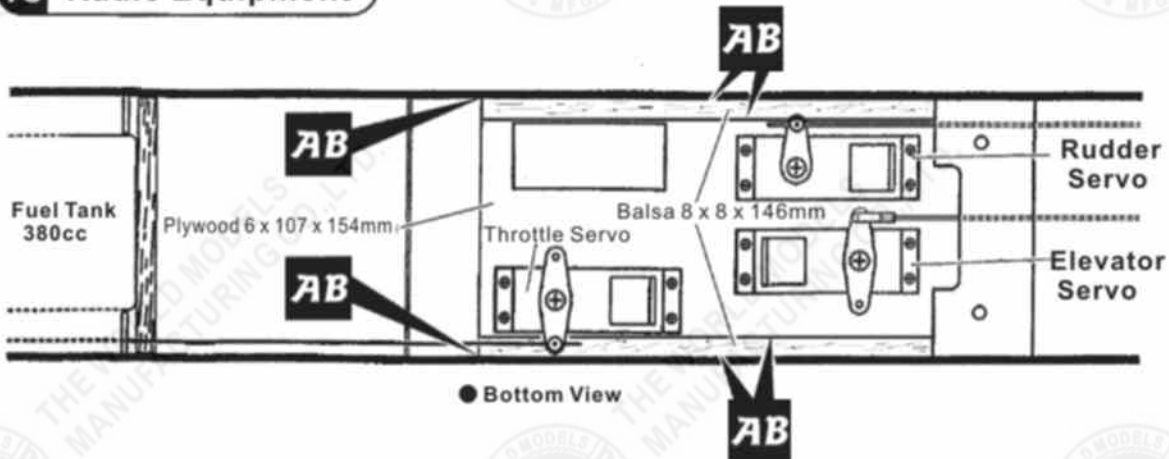

19 Radio Equipment

● Install Sponge for inserting Battery and Receiver.

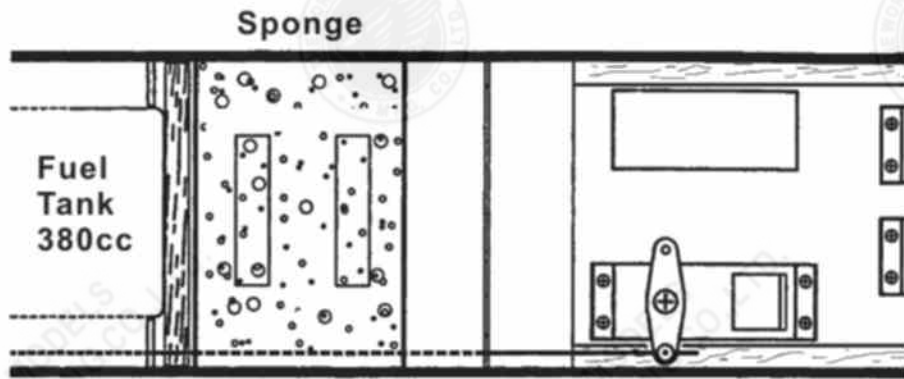

● Bottom View

20 Rudder Pushrod

PM 2 x 16mm Screw

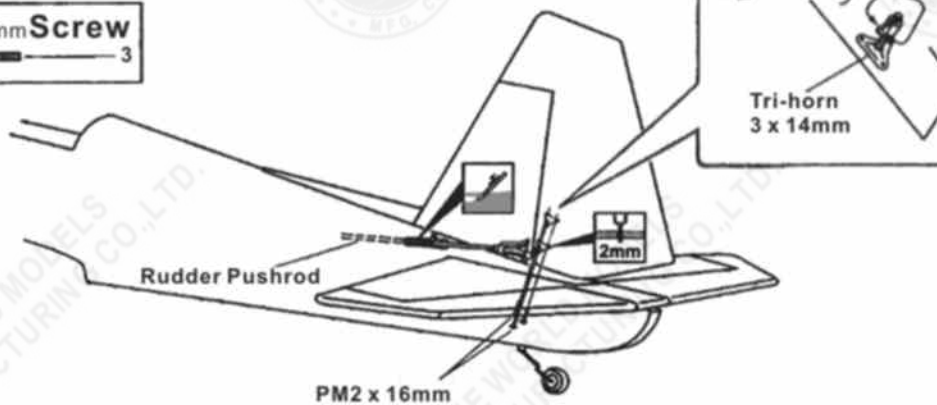

21 Elevator Pushrod

PM 2 x 16mm Screw



Ø1mm pilot holes for world models tri-horn pre-drilled. Please look for pin-hole marks at under side of control surfaces.

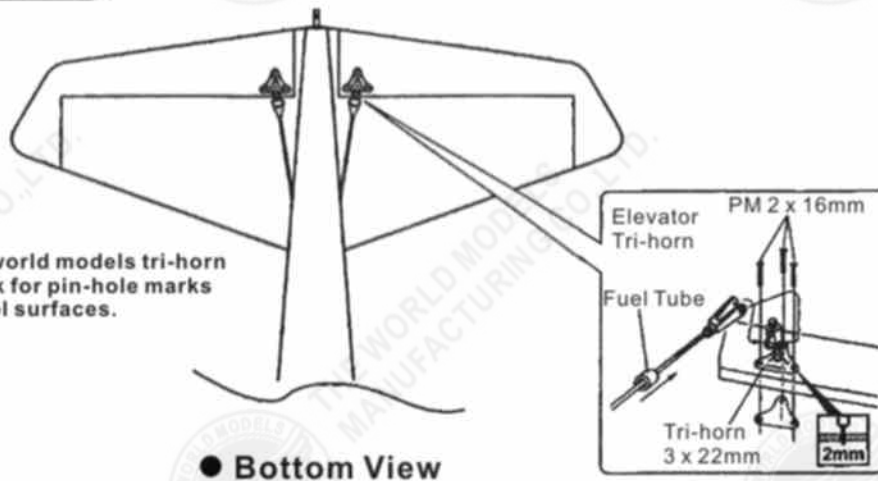

● Bottom View

22 Canopy

PWA 2.3 x 8mm Screw



d1.5 x D6.5mm Silicon Grommet

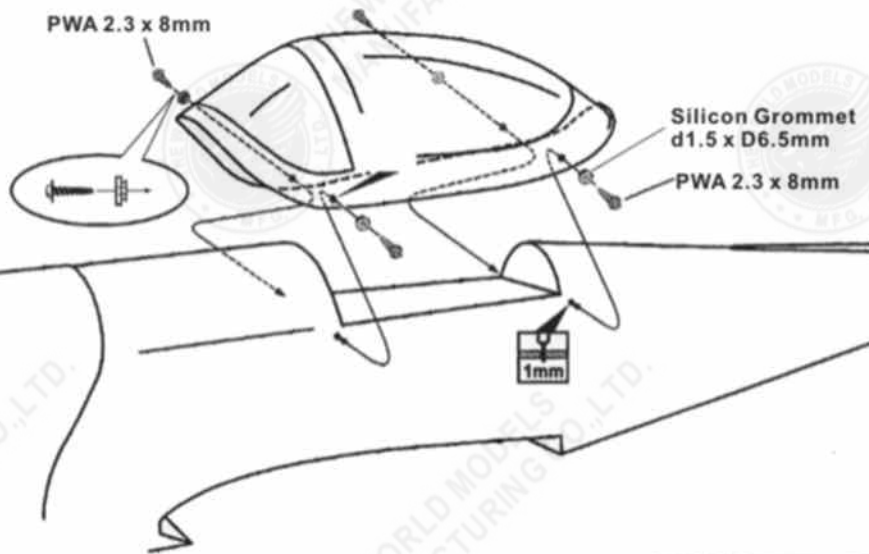

23 Main Wing

PM4 x 35mm Screw



d4 x D15mm Washer

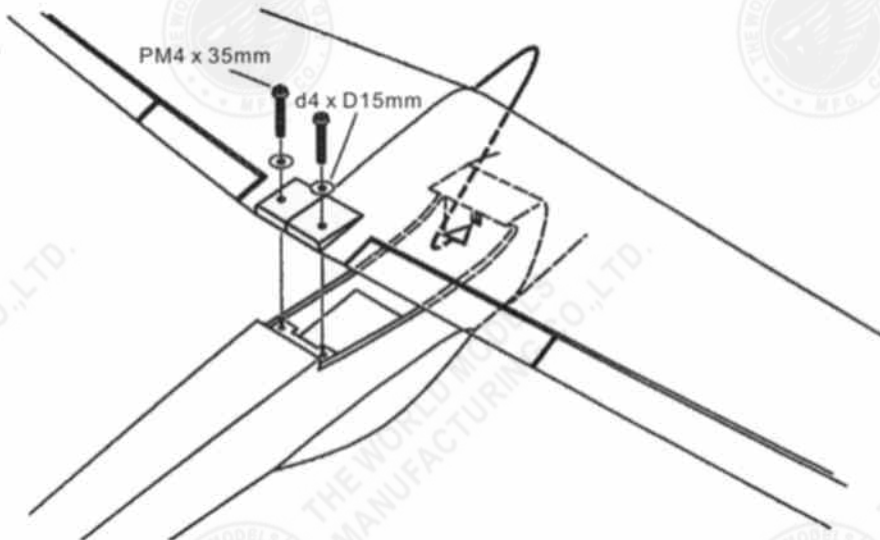

24 Wing Setting

Adjust the wing and fuselage configuration as in the diagrams.

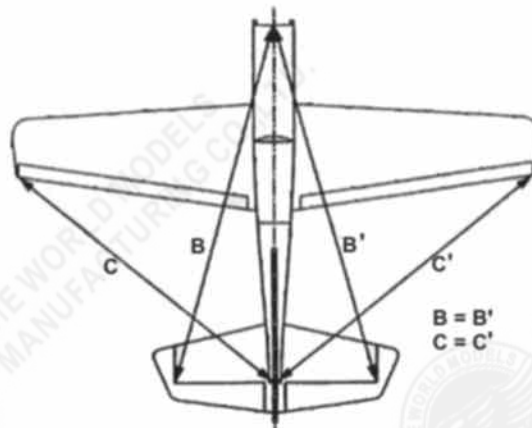
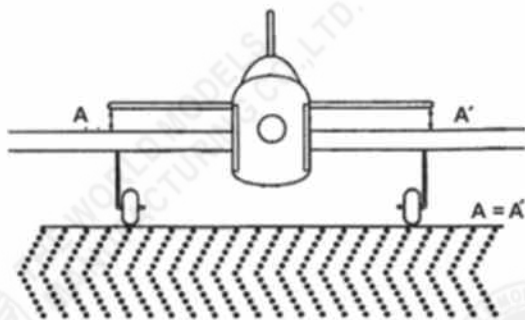

25 Control Throws

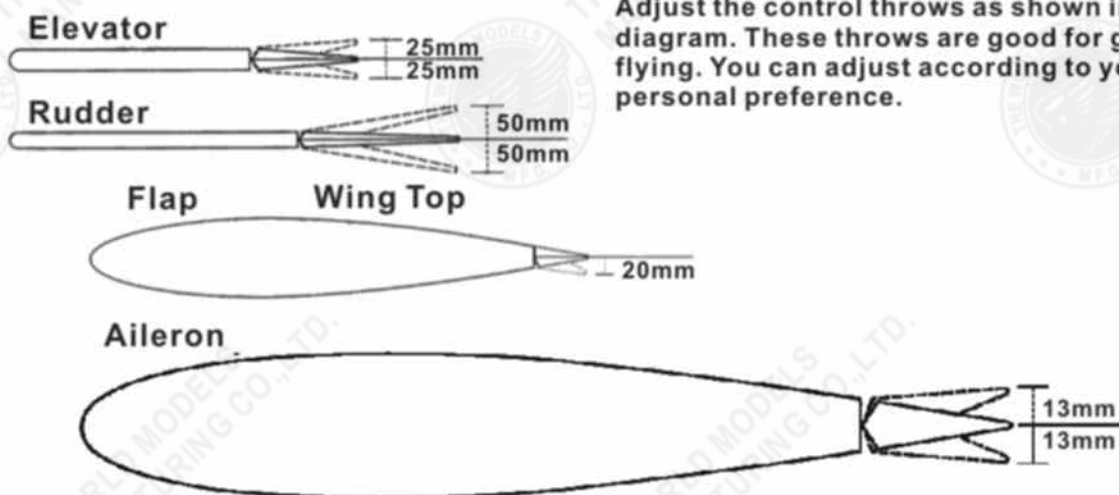

Adjust the control throws as shown in the diagram. These throws are good for general flying. You can adjust according to your personal preference.

26 C.G.

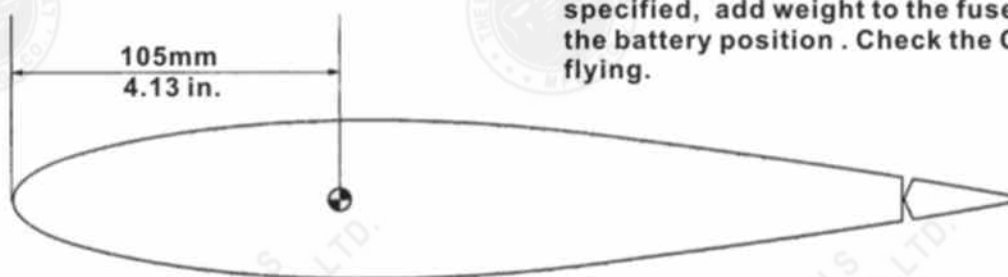

The ideal C.G. Position is 105mm (4.13 in.) behind the leading edge measured at where the wing meets the fuselage. In order to obtain the C.G. specified, add weight to the fuselage or move the battery position. Check the C.G. before flying.

! Warning!

Important Safety Precautions

- #First time flyer should never fly by himself / herself. Assistance from experienced flyer is absolutely necessary.
- #Pre-flight adjustment must be done before flying, it is very dangerous to fly a badly pre-adjusted aircraft.
- #**Super Chipmunk - 90S** is specially designed to be powered by 2C 0.60 or 4C 0.90 engine, using a more powerful engine does not mean better performance. In fact, over powered engine may cause severe damage and injuries.
- #Make sure the air field is spacious, never fly the plane too close to people and never get too close to a running propeller.
- #If you find wrinkles on the covering as a result of weather changes, you can use hot iron to remove the wrinkles. Please begin with lower temperature setting and gradually raise the temperature until the wrinkles are gone. Too hot an iron may damage the covering.
- #When Flaps are lowered, nose of model will rise. The nose-up varies with the speed at which the model is flying when you lower the flaps and the extent to which they are lowered. Check effect of flaps at higher altitude to avoid surprises during landing. You may apply down trim of the elevator to compensate for the nose-up effect when lowering the flaps. Taking off with flaps lowered is not recommended, as the increased drag may require a longer runway and more engine power for the model.

NEW